



RAALEBUG SWEEPER

Rugged. Ready. Rolling.



www.raalebborg.co.za

ALL-IN-ONE

Engineered for **all-in-one convenience** and efficient performance, the Raalebug Sweeper is designed to get the toughest jobs done, with ease. Perfect for city streets, shopping malls, car parks, office parks, housing developments, pedestrian walkways and more.



**DUAL, HEAVY DUTY
SWEEPING ROLLER
BRUSHES**

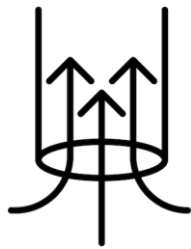

**POWERFUL
SUCTION
&
COLLECTION**



**HIGH PRESSURE
CLEANING**

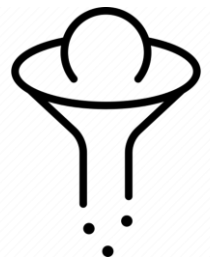

**SAND & COVER
SPREADER**

Whether it's clearing litter from a busy taxi rank, polishing the paving outside a shopping centre, or keeping suburban roads free of debris, the Raalebug Sweeper's agile size, precise manoeuvrability and multipurpose action offer endless applications.

MULTI-USE

The Raalebug Sweeper is designed to be **simple to operate, capable and highly flexible.**

One common hydraulic system powers all the sweeper attachments, allowing it to be operated by one person independently, taking on a multitude of sweeping, clearing and cleaning tasks.



SWEEP



COLLECT



CLEAN



COVER



STREETS
&
SIDE
WALKS

WARE-
HOUSE
&
FACTORIES

MALLS
EVENTS
EXPO'S

PARKING
AREAS

HOUSING
ESTATES

OFFICE
PARKS



FEATURES

The Raalebug Sweeper boasts **technical advancements** like independent brush control (opening and closing) with built in obstacle avoidance. Brush height is also fully adjustable, with anti-dust-mist-spraying, during operation.

HIGH POWER SUCTION & SWEEPING ACTION

HEAVY DUTY STEEL WIRE NYLON BRUSHES

SPRAY DEVICE + HAND HELD SUCTION HOSE

ANTI CLOG + AUTO DRAINAGE

VARIABLE CLEANING WIDTH

VARIABLE BRUSH SPEED

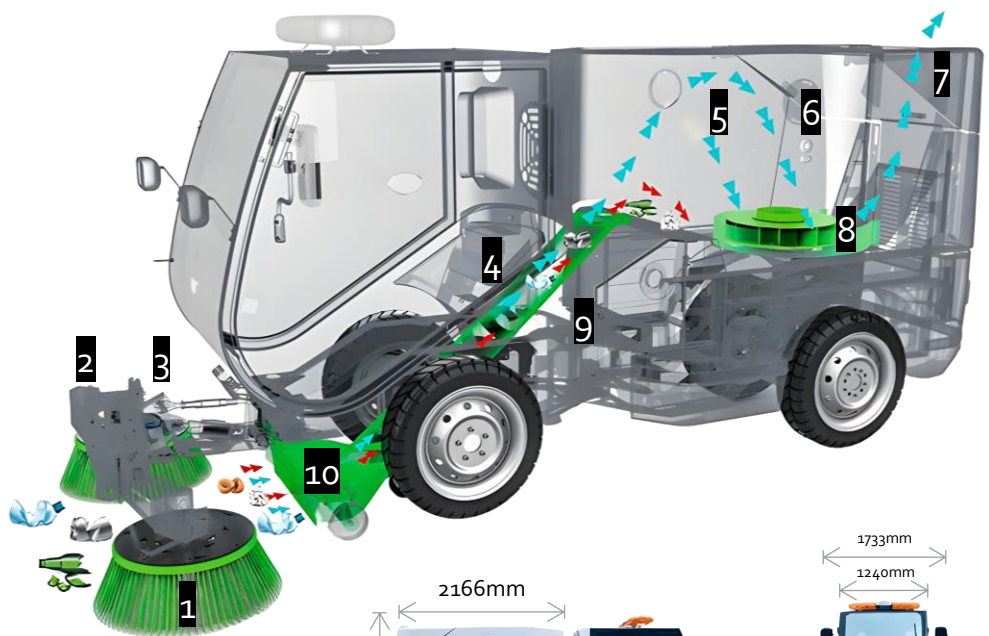

1	Adjustable Brushes
2	Mist Dust Sprinklers
3	High Pressure Washing
4	Garbage Pipeline
5	Double Rotation Suction
6	Garbage Filter
7	Air Outlet
8	Turbine Fan
9	Articulated Chassis
10	Garbage Suction Port

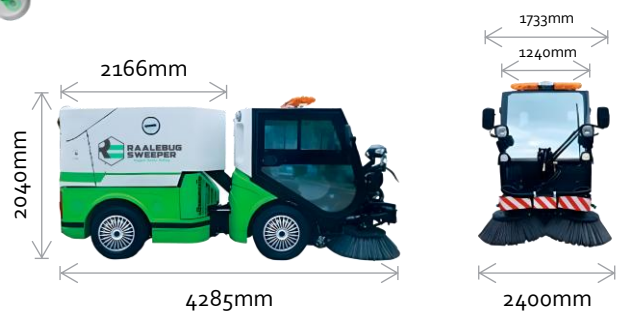

Versatility is at the heart of the Raalebug Sweeper: The hopper can be removed and replaced with a 1000L water tank, for high pressure washing.

Sand spreading is also available in 260L and 1000L capacities, respectively.



OVERVIEW

The Raalebug is **the small sweeper that's big on features**. Expect a heavy duty articulated chassis, panoramic-view driver cab, front and rear driver recorder, aluminium recovery box (hopper), air conditioning and the ability to add various cleaning attachments, for any requirement.

ERGONOMICS

Dual Seats

Ample space for two operators.

Electronic Control Start

Simplifies operation with an easy-to-use electronic control start system.

Integrated Steering Gear

Combines all display instruments, warning lights and control buttons.

Ergonomic Control Panel

Functional operation switches designed for easy and fast operation.





Safety Features

High-definition reverse camera and warning lights to alert passersby; one-click air intake baffle operation for debris of various sizes.

DRIVETRAIN

A 404EA-22 British Perkins Engine, for reliable, fuel-efficient performance.



	Power	36.3kW
	Engine	4 Cylinder / 2.2L
	Fuel Type	Diesel
	Driving Speed	26km/h
	Operating Speed	5 – 10km/h

MULTI-PURPOSE SWEEPER

1.6m - 2.4m	1.5m ³	700mm	Multi Function
Adjustable Sweeping Width (with Buffer Protection)	Hopper Capacity	Suction Head Width	Supports Multiple Attachments



HEAVY DUTY SWEEPING
ROLLER BRUSHES



HIGH PRESSURE
CLEANING

QUICK DISASSEMBLY HOPPER



SPECIFICATIONS

The Raalebug Sweeper is sold, distributed and supported by **Raaleborg Environmental, Pty Ltd.** Raalebug Sweepers are available for sale, or for lease, under management. All Raalebug Sweepers are fully supported, with end-to-end after sales servicing, maintenance and parts.

DIMENSIONS

- Dimensions (Length × Width × Height)
- Including Brush: 4285 × 1400 × 2040mm)
- Without Brush & Warning Light: 4070×1240×1880mm
- Wheelbase Front / Rear: 920mm
- Wheelbase: 2040mm
- Minimum Ground Clearance: 200mm
- Maximum Cleaning Width: 2400mm
- Hopper Bin Capacity: 1.5m³

WEIGHT

- Curb Weight: 2370kg
- Front Axle No Load: 1320kg
- Rear Axle No Load: 1050kg
- Maximum Gross Mass: 3100kg

PERFORMANCE

- Maximum Cleaning Width: 2.4m
- Working Speed: 8 - 12km/H
- Maximum Travel Speed: 26km/H
- Maximum Cleaning Capacity: 28800m²/H
- Cleaning Efficiency: 96%

POWERTRAIN

- Drive Form: Hydraulic Four-Wheel Drive
- Tire Model: 195/75R16
- Number Of Tires: 4
- Tire Pressure: 0.46mpa
- Wheel Nut Torque: 124 ~ 165nm

ENGINE PARAMETERS

- Manufacturer: Perkins (Four Cylinder)
- Engine Model: 404D-22
- Engine Displacement: 2.216l
- Rated Power/Speed: 35.7kw / 2600rpm
- Engine Working Speed: 1600rpm
- Fuel Type: Diesel
- Standard: EU Standard EC Stage IIIA

STEERING SYSTEM

- Steering Form: Articulated Body Steering
- Steering Gear Type: Full Hydraulic Steering
- Steering Mechanism Form: The Front & Rear Frames Are Articulated & Connected To The Steering Cylinder To Push

HYDRAULIC SYSTEM

- Hydraulic Oil Grade: Texaco Rando HDZ 46
- Hydraulic Fluid Cleanliness: NAS9
- Hydraulic Tank Capacity: 60L

ELECTRICAL SYSTEMS

- Composition: Road Sweeper Driving System Circuit & Control System Circuit
- System Voltage: 12V
- Battery Capacity: 80AH

CLEANING SYSTEM

- Form: Two Disc-Shaped Brushes, Symmetrically Arranged In Front
- Brush Disc Diameter: 850mm
- Each Group Contains 14 Steel Wires & 12 Nylon Brush Wires, Each With A Length Of 630mm; 30 Groups Per Circle

SUCTION SYSTEM

- Straw Length: 4200mm
- Straw Inner Diameter: 180mm

HIGH-PRESSURE WATER GUN

- Maximum Water Pressure: 140bar
- Flow Rate: 8.3L / Min

HOSE REEL

- Hose Length: 10m

DISCLAIMER:

Features and specifications are subject to change depending on market and grade. Images used are for illustration purposes only and may differ to the actual product.

CONTACT



RAALEBUG SWEEPER

Rugged. Ready. Rolling.



Raalebug Sweeper (Multifunctional Road)



(Electric)



Raalebborg
Environmental (Pty) Ltd

Head Office: 24 Fiskaal Street, Kempton Park, South Africa, 1620

Telephone: +27 (0) 82 553 2833

Email: info@raalebborg.co.za

For more information please visit <https://raalebborg.co.za/>

